

SOUND STANDARD	std 0	std 1
L (AM 6.5MHz)	0V	0V
B/G (FM 5.5/5.74MHz)	0V	5V
D/K (FM 6.5MHz)	5V	0V
M (FM 4.5MHz)	5V	5V

DC VOLTAGES ARE MEASURED WITH DIGITAL METER IMPEDANCE 1kΩ
 USE COLOURBAR TEST CHART A2 STEREO SIGNAL, CHANNEL 12
 INDIVIDUAL DIFFERENCES IN MEASURED VOLTAGES MAY OCCURE.

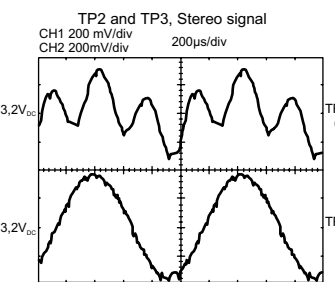

5028F12GR

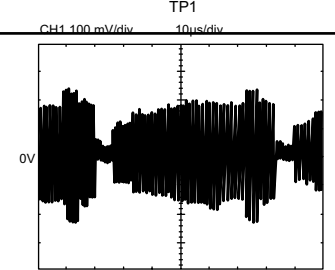
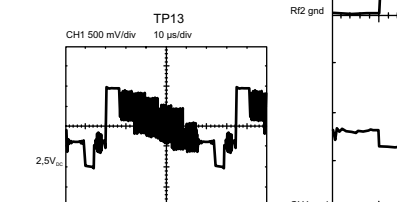
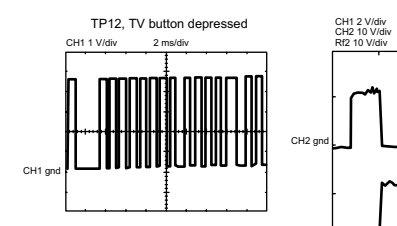
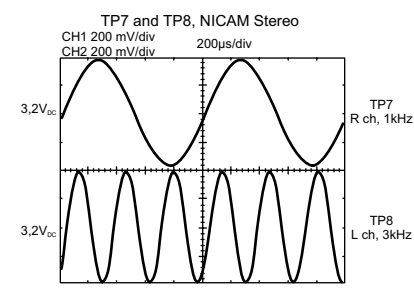
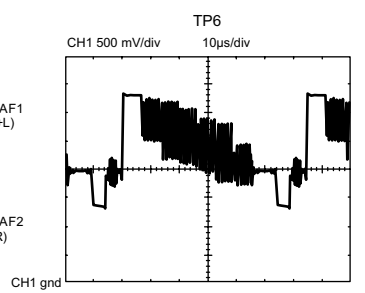
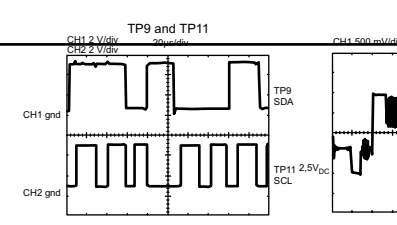
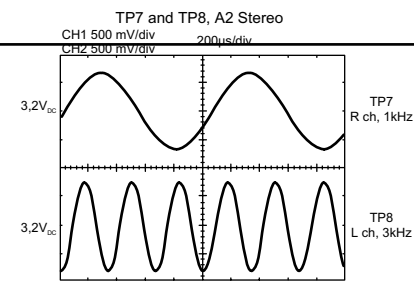
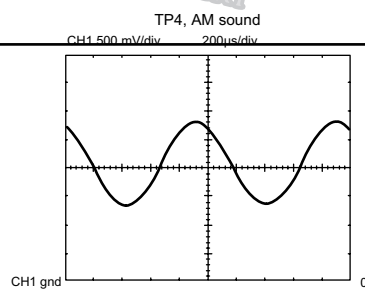
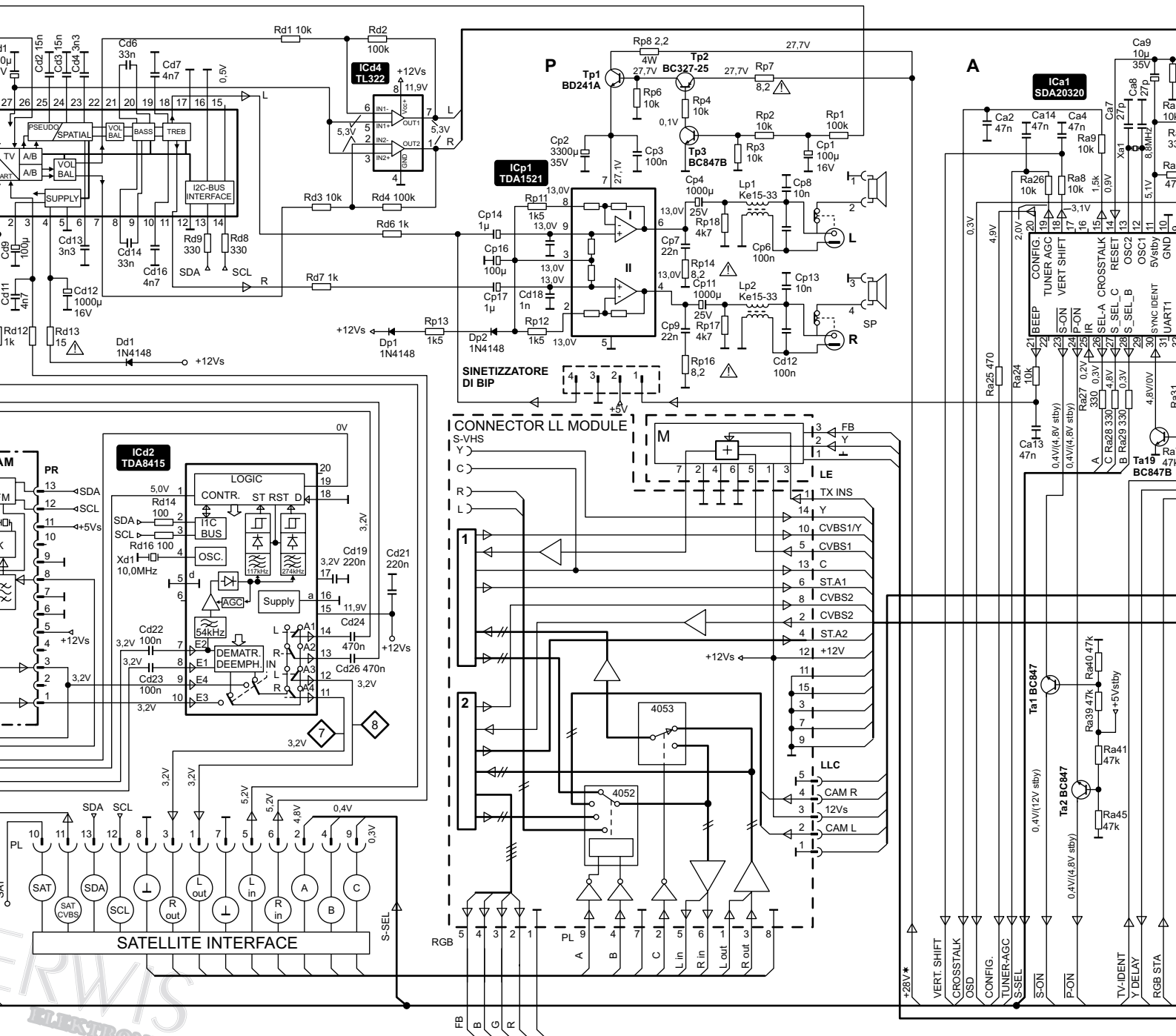

COMPONENTS FOR NTSC 3,58 VIA SCART
AB 51* ONLY

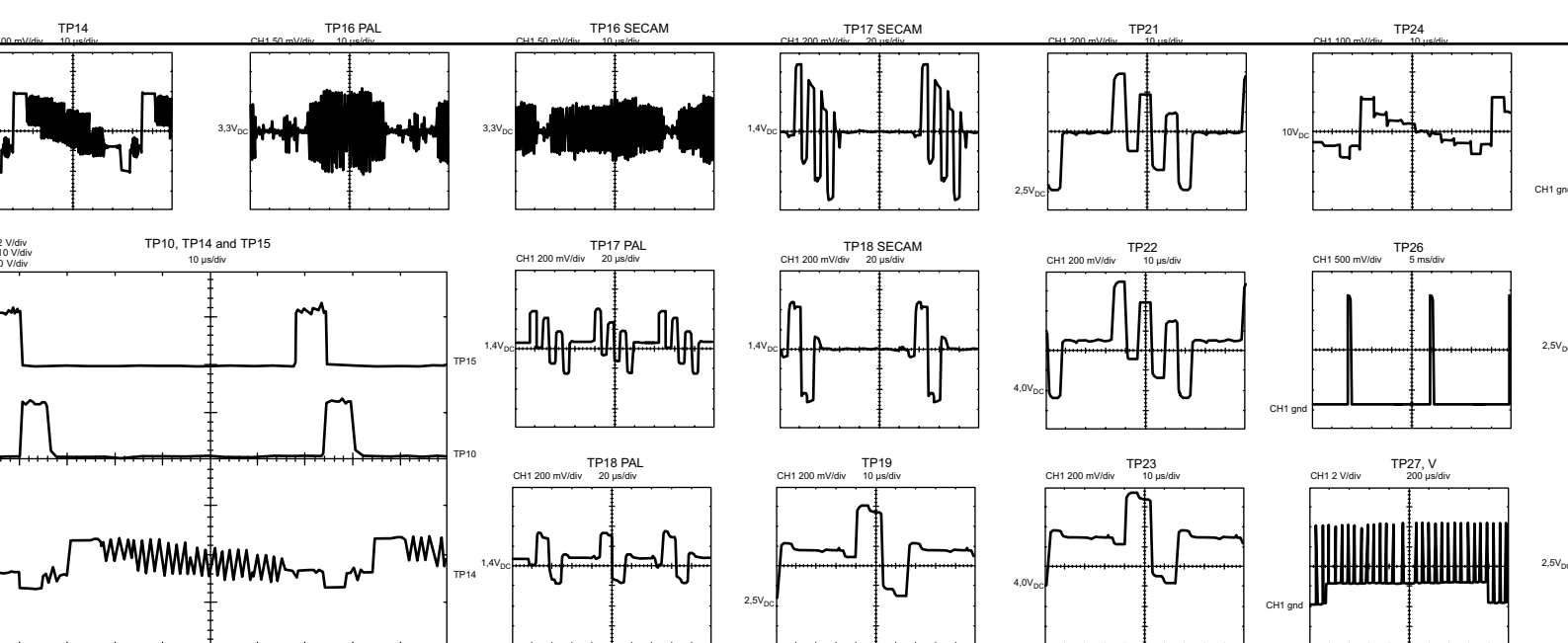
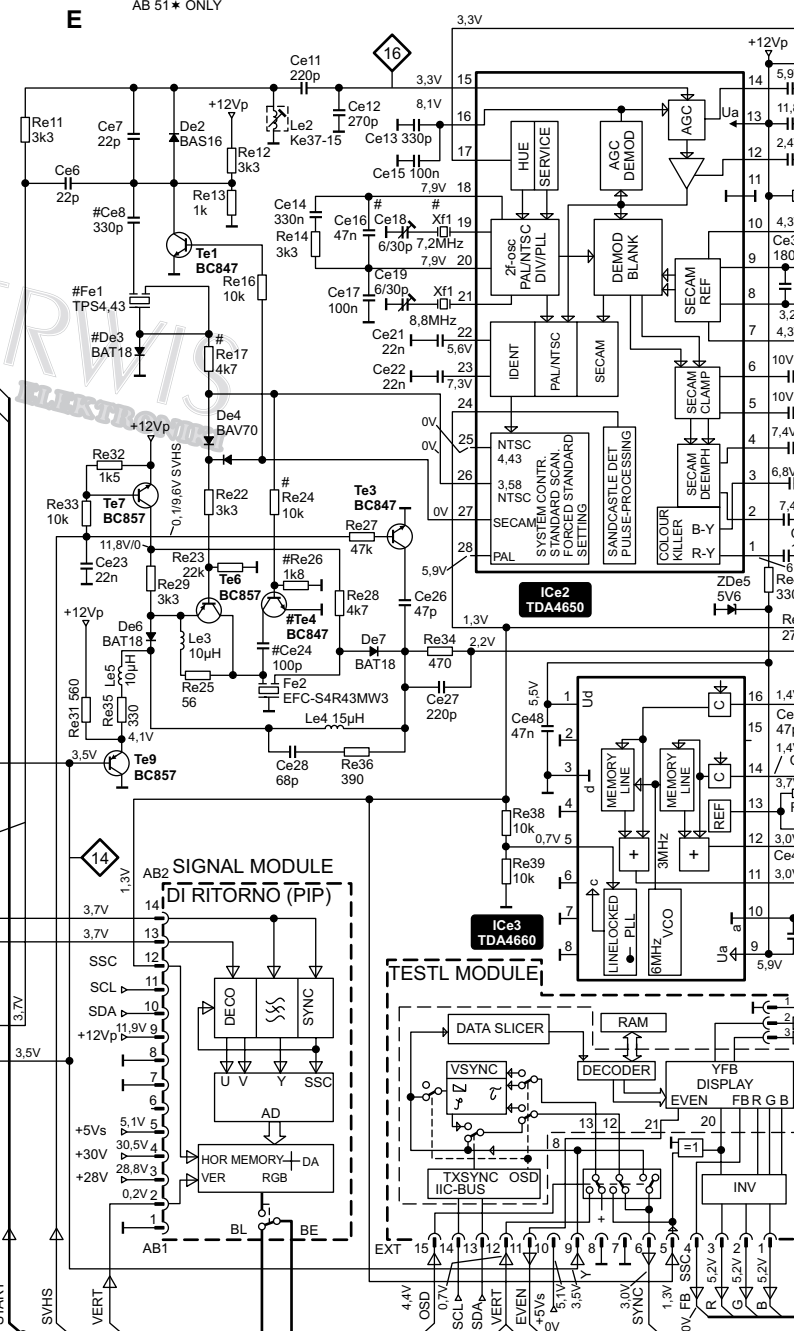
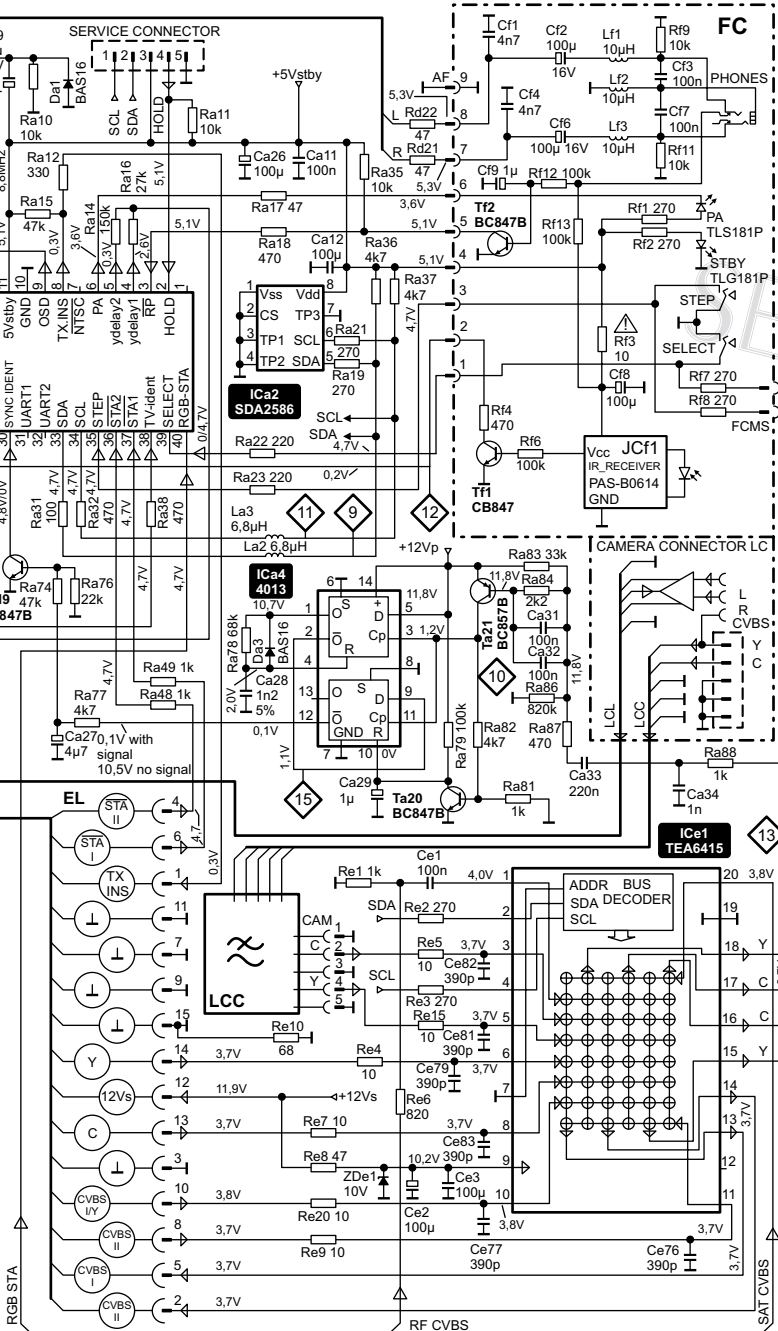

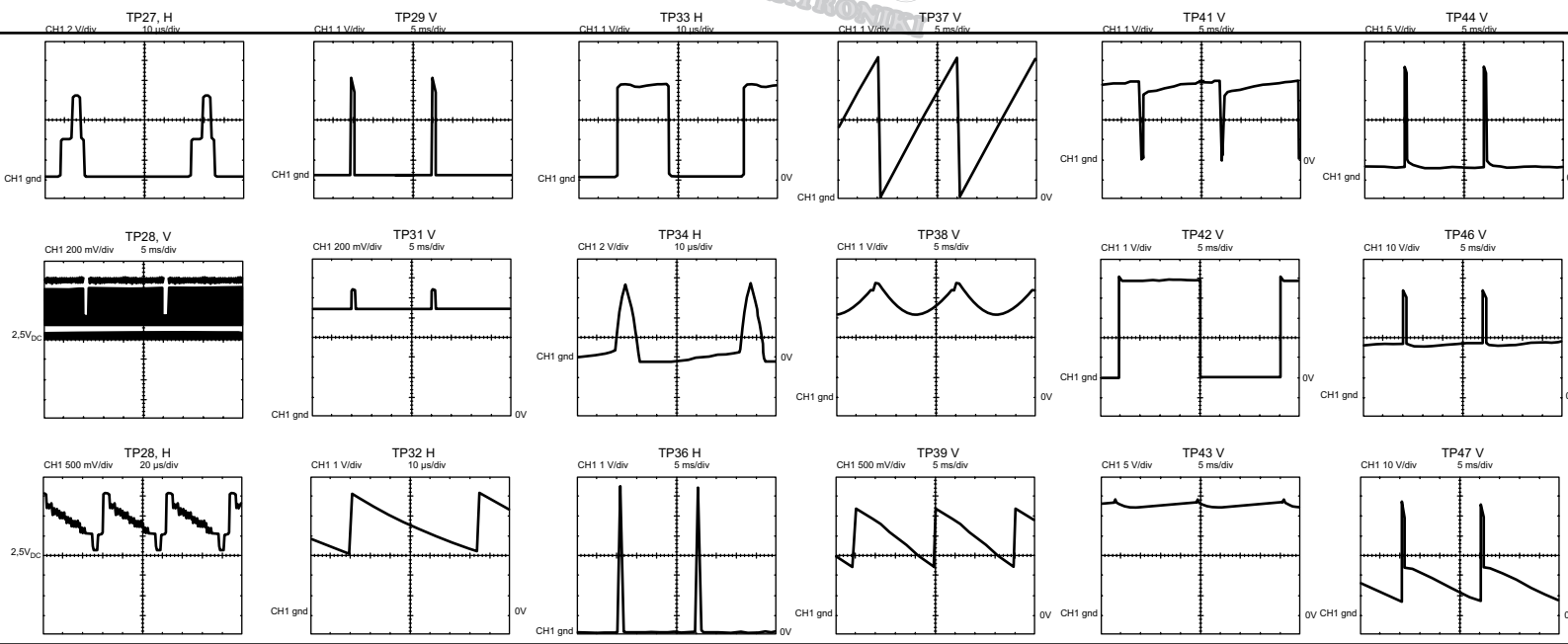
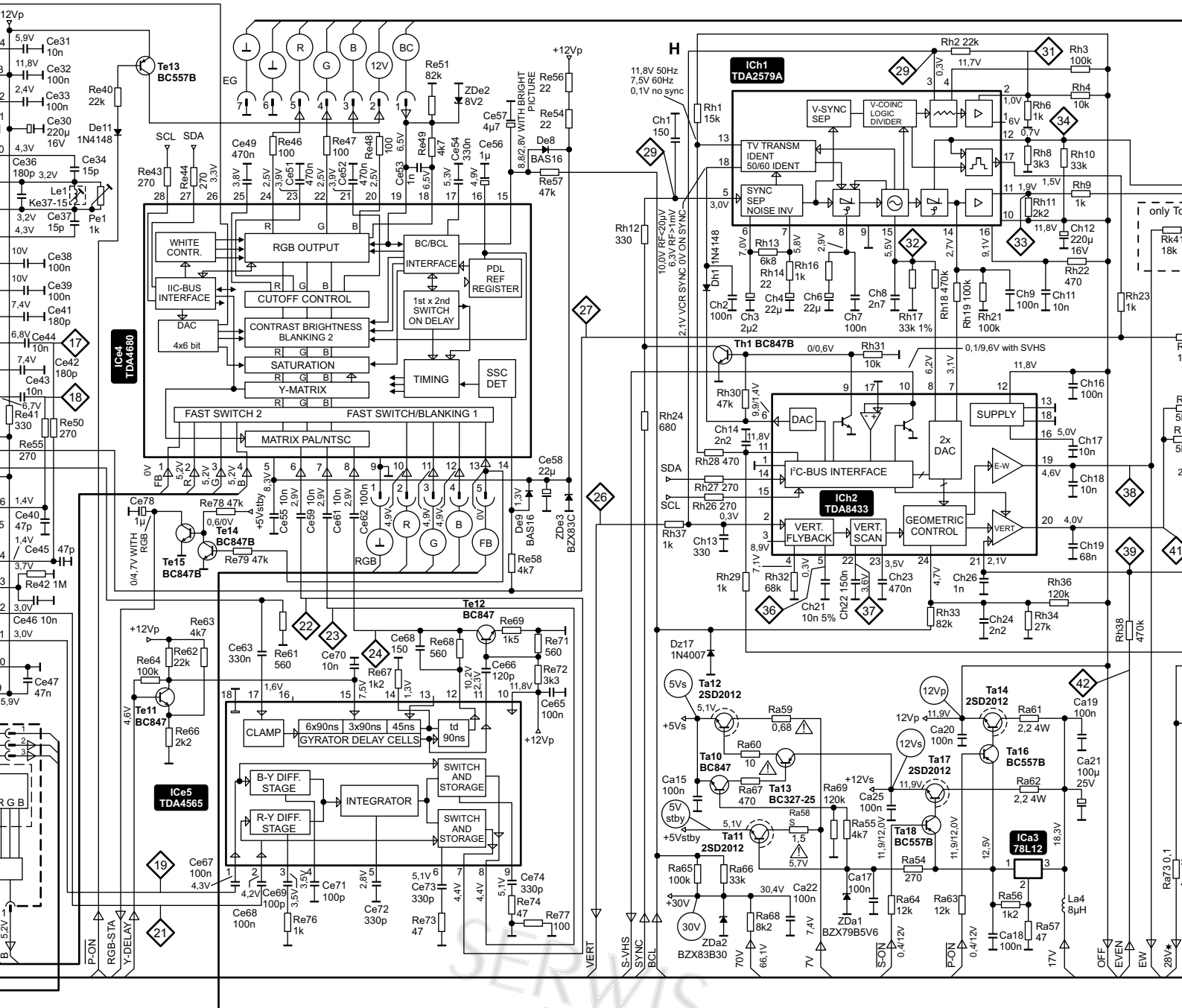

** VARIABLE COMPONENTS FOR CRT TYPES

AB	CRT	Vs500	PC500	Rk6	Rk8	Rk11	Rk14	Ra65	Ck1
5*2	Philips BL	No	No	4k7	220	1,2	1k	100k	100µ
5*5	Philips FST	No	No	4k7	220	1,2	1k	100k	100µ
5*0	Toshiba 24" 28"	YES	No	6k2	470	1,8	220	100k	22µ
5*3	Toshiba 21"	No	No	4k7	470	2,7	220	100k	22µ
5*1	Videoc MP	No	No	4k7	470	2,7	220	100k	22µ
5*4	Videoc SP	No	YES	4k7	470	2,7	220	100k	22µ

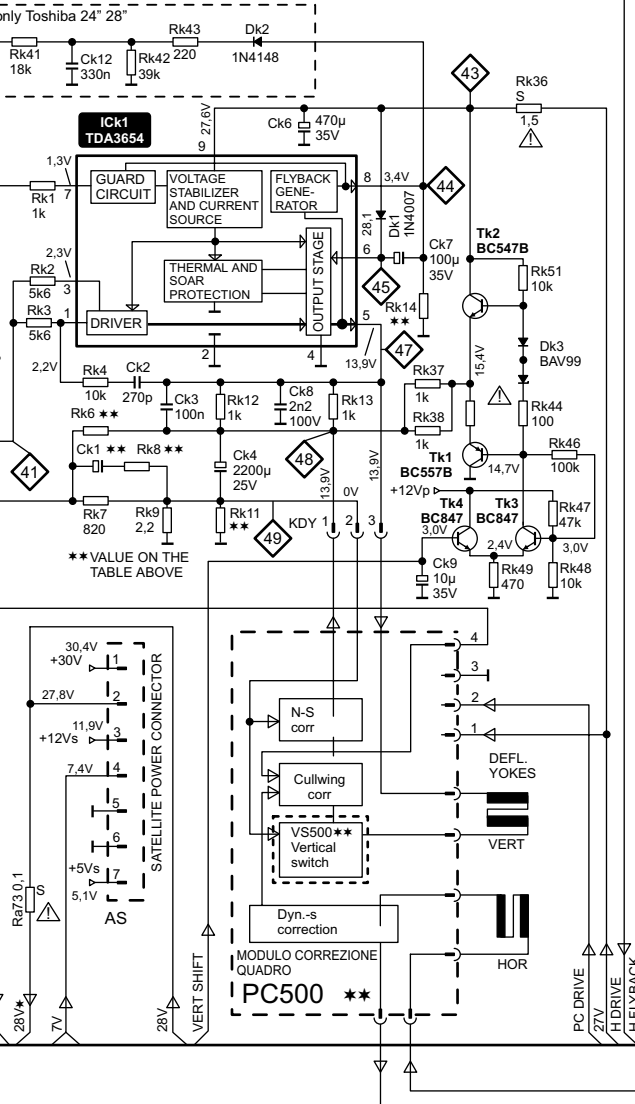

SERWIS ELEKTRONIKI

